

Burns and Ferrall Locations

AUCKLAND
 12 Reg Savory Place
 East Tamaki, Auckland

0800 697 465

WELLINGTON
 122-124 Tory Street
 Te Aro

HAMILTON
 60 Alexandra Street
 Central

CHRISTCHURCH
 345 St Asaph Street
 Christchurch

**Product Specification Sheet
 DIM440R10**

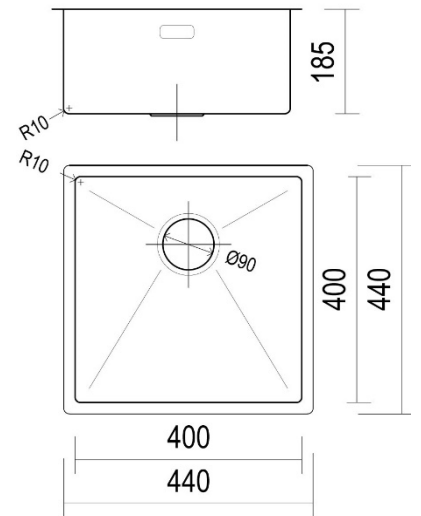
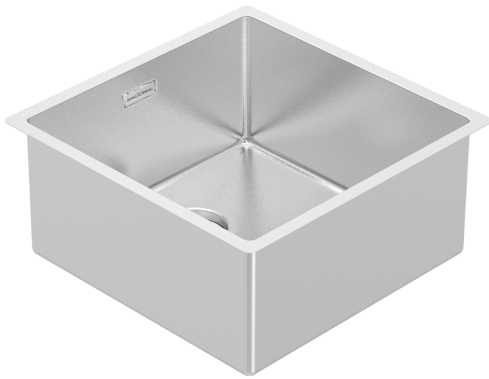

Designer R10

B&F Designer R10 400 Single Bowl

Models	Corner Radius
DIM440R10	10mm
Overall Dimensions W x D	Waste
440 x 440mm	90mm
Bowl Dimensions W x D x H	Installation
400 x 400 x 200mm	Undermount
Material & Finish	Minimum Cabinet Size
1.2mm 304 Stainless Steel, DIAMOND FINISH	520mm

Accessories Available (optional)



E&OE – it is recommended all measurements are taken directly from the product. Specification subject to change without notice, always consult the literature supplied with the product. Coloured images are indicative only.